

# Series DAO

## Open Frame, Dual Pinch, Pneumatically Operated

- Available in Full Round or Pre-Pinched construction.
- Light weight
- Low pressure drop
- Drop tight closure
- On/Off or throttling service
- Fail Open or Fail Closed pneumatic actuators

### Specifications:

- Flanges: ANSI STD 125/150 lbs
- Stem & Guide rods: 303 stainless steel

### Options:

- Epoxy paint
- Sleeve elastomer
- Valve length
- 316 stainless steel stem
- Positioner
- Solenoid valve
- Limit switches

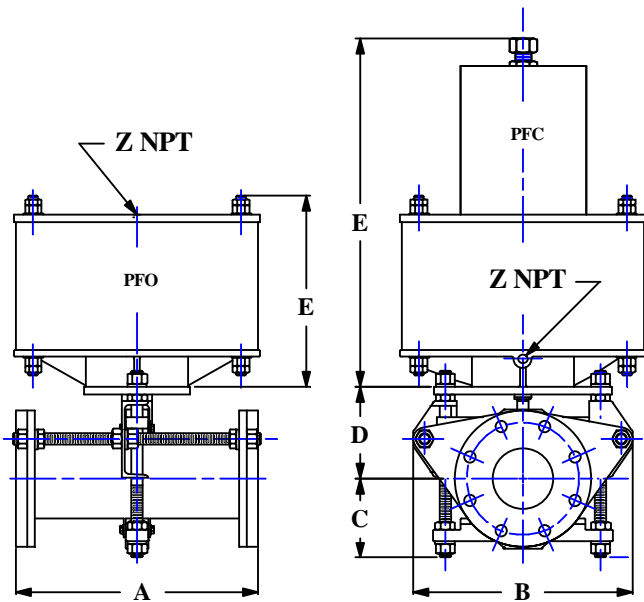

All Dimensions Are in Inches.

SIZE	21	30	36	40	70	80	120	200
E PFO	10.2	13.5	14.7	19	21	23.6	29	32
E PFC	27.4	34.6	37.2	62.3	45	52.6	65	74
F Dia	11	13	16.2		18.2	18.5	24.5	30
Z NPT	1/4 NPT		3/8 NPT		1/2 NPT			
Wt PFO	46	75	119	130	140	145	200	275
Wt PFC	70	156	226	300	355	385	450	575

SIZE	1	1.50	2	2.50	3	4	5	6	8	10	12	14	16	18	20	24
A-S	4	4.75	5.25	5.75	6	8	-	12	16	20	24	28	32	36	40	48
A-M	5.50	6	7	7.50	8	9	10	17.7	21.3	26.5	29					
A-L	6	6.50	8	10	12	16	15	18	24	30	36	42	45	54	60	72
A-XL	-	-	-	-	-	-	-	24	32	40	48		48			
B	5.5	5.25	7.12	9	10	12.5	16	16.3	19.5	24	27.5	35.5	42	48	12.5	16
C	2.12	2.50	3	3.50	3.7	4.50	5	5.50	6.75	8	9.5	14	17	18	19	20
D	9.62	9.75	10.5	12	14	18	18	19	25	26	27	27	27	30	36	40
P Max	150 psi				100 psi				75 psi				50 psi			
Wt, Lb.	15	16	30	35	47	75	100	130	180	300	420	540	980	1100	1200	1600