

# Series CEP

## Pre-Pinched, Single Pinch, Enclosed Construction, Electric Actuator Operated

- Low pressure drop
- No packing
- Drop tight closure
- On/Off or throttling service
- Long lasting compression molded sleeve

**Applications:** Ideal for automatic control of abrasive, viscous, and corrosive fluids including wastewater, mine slurry, chemicals, cement, pulp, powder and pellets.

**Operation:** The CEP is a pre-pinched on centerline, single pinch electric operated valves. An electric motor drives a single pinch bar from the top against the rubber sleeve to pinch off flow.

**Construction:** Actuators are available with single and 3-phase motors. All electric actuators come with auxiliary hand wheel. 3-phase actuators come with reversing contactors, power supply, limit and torque switches, push buttons, selector switches and pilot lights.

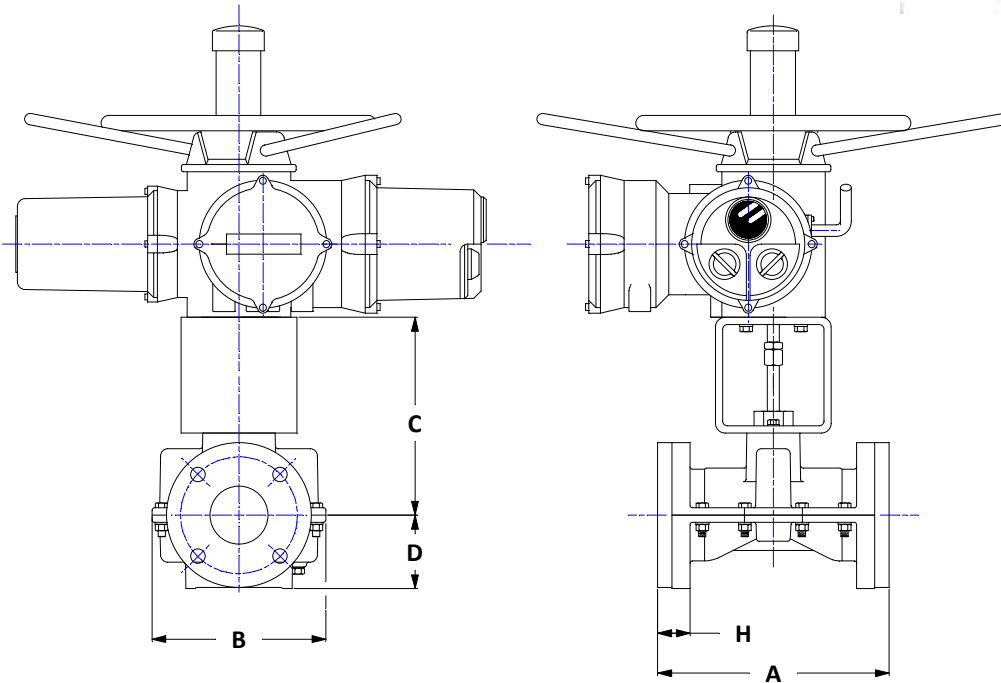

### Specifications:

- Flanges: ANSI STD 125/150 lbs.
- Housing: Cast iron, ASTM A48, Class 35
- Stem & Pinch bar: 303 stainless steel
- Bearing: Bronze alloy

### Options:

- Epoxy paint
- Sleeve elastomer
- ANSI STD 300lbs. flange
- 316 stainless steel stem
- Secondary containment package
- Positioners
- Limit switches

All dimensions are in inches.

SIZE	4	6	8	10	12	14	16	18	20	24
A	9.00	17.75	21.37	26.50	29.00	28.00	32.00	36.00	40.00	48.00
B	13.5	20.12	22.75	26.25	32.00	34.37	40.50	43.75	50.50	60.50
C	10.56	12.68	17.43	20.50	22.68	23.68	28.12	29.12	37.65	42.25
D	4.62	5.75	7.00	8.25	9.75	13.68	16.12	17.12	19.65	22.25
H	1.31	1.87	1.61	1.81	2.25	2.75	3.37	3.37	3.50	3.50
P Max	150 psi			100 psi						
Wt, Lb	90	150	350	550	800	1,000	1,700	2,000	3,000	4,300