

# **ONYX VALVE CO MODEL DAO-PFC**

## **Installation & Maintenance**

### **OPERATION:**

**(4-2010)**

The Onyx DAO-PFC pinch valve is an open frame valve without housing enclosure and fails closed on loss of air. The actuator drives a direct acting pinch bar (or a pair of pinch bars in case of full round port) to close the rubber sleeve bubble tight. Positive opening tabs molded into the sleeve attached to the pinch bar insure complete opening.

The pneumatic actuator offers the advantage of automated operation. When equipped with a positioner, the DAO valve is an efficient reliable throttling control valve.

The air bag actuator has no piston rings to wear, and no diaphragm, assuring the user high efficiency, low hysteresis and good sealing characteristics. Actuators are rated at 125 psi maximum supply air pressure.

### **TESTING:**

All Onyx pinch valves are tested to customer specifications before shipment. Unless otherwise specified, all valves are shipped assembled with all accessories piped, mounted, and calibrated.

### **STORAGE**

Correct storage extends valve life. The rubber sleeve in the valve is perishable. Ideal storage conditions are 50°F and 60% relative humidity.

1. Keep valves and spare sleeves as cool as possible. They can be stored in an unheated area, but allow maximum ventilation in storage areas subject to high ambient summer temperatures. Truck trailers and storage sheds become incredibly hot during summer months. Avoid such locations.
2. Avoid sunlight. Ultra-violet light accelerates the deterioration of rubber. Leave the valve in its box. If not feasible to box the valve, cover the sleeve with black plastic.
3. Avoid ozone. **DO NOT STORE** valve near active electrical equipment. For long term storage, coat the face and inside the sleeve with silicone spray or liquid.

### **CONSTRUCTION**

Actuator housing is PVC and cast iron. Valve and actuator stem are 303 Stainless Steel. Pinch bars are ductile iron, ASTM A536-80, class 65-45-12.

## INSTALLATION:

1. Safety considerations.
  - a) Process fluid: Open frame pinch valves are designed to handle benign fluids such as storm water, sand and water solutions, mine tailings, etc. When the sleeve wears out, you can expect that the process fluid will spray out in the vicinity of the valve. Make sure that this is acceptable.
  - b) **WARNING: Open frame pinch valves are NOT designed to control acids, caustic, scalding hot, toxic, or flammable or other hazardous fluids. When the sleeve wears out in an open frame valve, process fluid is going to spray out all over the place. Hazardous fluid escaping from the valve can cause serious injury and/or property damage.** Always use an enclosed valve with secondary containment option for hazardous or noxious fluids.
  - c) Leakage: Consider the possibility of flange leakage due to improper tightening of flange bolts. Pinch valves handle abrasive fluids; it may be reasonable to expect the sleeve to eventually wear out. Precautions should be taken where liquids may drip onto electrical equipment or plant personnel, or where combustible fluid may drain into a dangerous area.
  - d) After shut down: Pinch valves seat can hold pressure in a system for considerable time. Means should be provided to safely relieve pressure and drain lines.
2. **Flanges:** Onyx pinch valves are designed to work with standard ANSI 150# (or 300#) **flat face** flanges. No gasket is required; the sleeve face *is* the gasket. Be careful when using Victaulic type flanges, as the grooving machine often leaves a sharp edge inside the flange. This sharp edge will cut the rubber valve sleeve causing premature sleeve failure. Make absolutely sure that the inside edges of mating flanges are filed or ground smooth. Valve flanges have through holes and are designed to have an ANSI hex (not heavy hex) nut behind the flange. Flange bolts must be inserted from the mating flange side.
3. On open frame pinch valves can be configured for full round and pre-pinched port. For full round full port opening, the actuator moves every time the valve cycles:
  - a) You must use flexible airlines to the pneumatic cylinder.

- b) You must use flexible conduit to connect to any electrical accessories such as solenoid valves, positioners, or limit switches which may be mounted to the pinch valve.
4. Allow a straight run into and out of throttling valves. A good rule of thumb is 10 to 20 pipe diameters up stream, and 3 to 5 pipe diameters down stream. (Refer to Fig. 1)

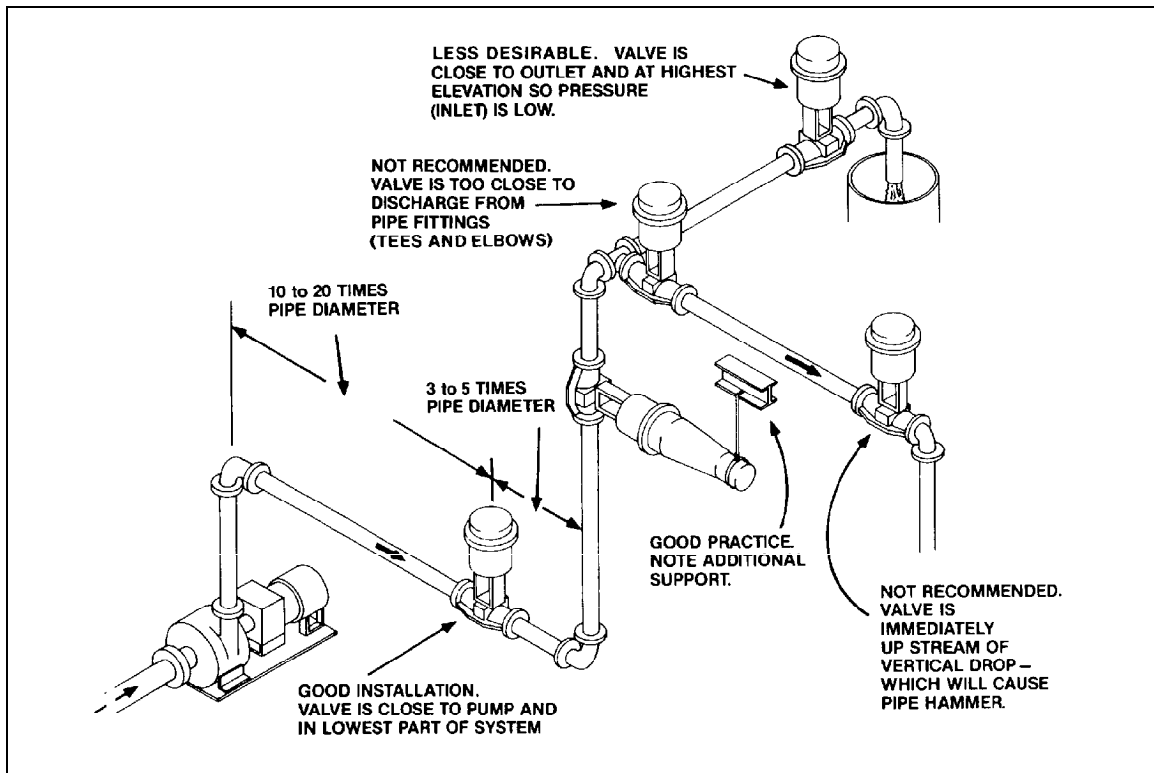

*fig 1*

5. Locate the valve where it can be reached for service and sleeve replacement. Allow access by technicians who may have to calibrate automatic valves. If valve is operated with an auxiliary hand wheel, allow access to the hand wheel. Locate valve so that operators can see relevant gauges.
6. Be sure pipeline is clean. Foreign material left in the pipeline can damage valves. Clean the mating flanges of adjacent pipe. Remove old gasket material.
7. Inspect valve before installation. Report shipping damage before installation. **DO NOT INSTALL A VALVE KNOWN TO HAVE BEEN DAMAGED IN SHIPMENT.** Check inside the valve to make sure no foreign objects are present.
8. Pinch valves can be installed in any position with flow in either direction. If the valve is installed with stem horizontal, outboard support is advisable. If is in a position other than upright, rotate actuator so the air connection points 'down' to facilitate draining condensation from air motor.

- i. Do not install valve next to a source of extreme heat.
9. Close valve prior to installation. Make sure adjacent pipe is properly aligned. Adjacent pipe must have sufficient travel to insert valve and draw tight to compress sleeve faces; valve will not stretch. Add an expansion joint if necessary to obtain required free play. Make certain adjacent pipe has sufficient free play to allow removal and reinstallation of the valve. (Flange gaskets are not required, but may be used for spacers if necessary.)
- i. Coat faces of valve sleeve with silicone lubricant to facilitate installation and later removal of the valve and to preserve the resiliency of the rubber.
10. Bolt valve into pipeline. Snug up the bolts gently in a criss-cross pattern. It may be necessary to re-tighten bolts later after the rubber has taken set.
11. **IMPORTANT - INSTALL SUFFICIENT PIPE SUPPORTS TO ISOLATE VALVE FROM EXCESSIVE FORCES.**

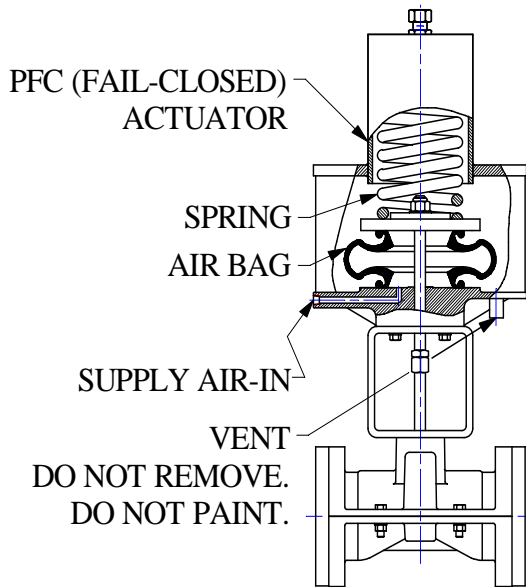

11. This is a single acting actuator.

It has a sintered metal breather vent on the bottom. Actuator cannot operate properly if this vent is not functional.

12. **Do not paint the breather fitting!**

## MAINTENANCE

1. Visually inspect valve periodically.
2. Lubricate valve once a year. Coat stem (#7) with grease. If valve is in a dusty environment, grease may cause dust to stick to the stem: use light oil.

## SLEEVE REPLACEMENT

**WARNING:** Before attempting to disassemble the valve the stem must be in the retracted position. Failure to retract the stem could result in equipment damage and/or serious personal injury.

1. Relieve process pressure and drain process line.
2. Disconnect air and electric lines. Label and record connections so the valve can be reconnected in the same manner.
3. Remove valve from process line.
4. Disconnect any accessories attached to the stem or coupling.
5. Increase air pressure to the actuator to retract the stem. Keep the valve in the open position.
6. Remove positive opening tabs from upper and lower pinch bars (#9 & 10) by removing bolts, nuts and washers (#8A, 8B, 8C).
7. Remove the lower pinch bar by removing hex nuts, lock washers and jam nuts (#23A, 23C & 23D) from the guide rods (#23).

After the lower pinch bar is removed, slowly bleed the air from the actuator. This will push the upper pinch bar down to extract the sleeve.

8. If sleeve (#1) is provided with positive opening tabs (integrally molded tabs bolted to the pinch bar), follow steps 'a' through 'e' below. If no positive opening tabs are provided, proceed directly to step 11.

- a) Remove bolts, nuts and washers that secure the positive opening tabs to the pinch bar (8A, 8B, 8C). The sleeve (#1) is now free from the both pinch bars (#9 & 10). Discard old sleeve. Prepare new sleeve for installation.

- b) Punch holes through the positive opening tabs using a gasket or pliers type punch. The diameter of the holes in tabs should be approximately equal to hole diameter in pinch bar.

- c) Positive opening tab holes must be in proper alignment with respect to the flange face holes, or there will be hell to pay when you reinstall the valve. It is very difficult to twist the rubber sleeve to align these holes later.

- d) Replace tab bolts, nuts and washers (#8A, 8B & 8C). Use flat washers on every hole. If you replace bolts (#8A), cut or grind flush with nut (#8C) so bolts do not puncture sleeve in closed position.



- e) Trim the tabs even with the top surface of the pinch bar.
9. Apply a coat of silicone valve sealant to the mating flanges of the bonnet halves.
10. Coat the stem (#7) with a light application of grease or machine oil.
11. Insert new sleeve and reattach the lower pinch bar. (You will have to reapply pressure to the actuator to do this.) Replace the nuts on the guide rods.
12. Replace any accessories that were previously removed. Tighten all fittings and gauges.
13. Reinstall valve in process line.
14. Reconnect air lines.



### **WARNING**

The model PFC actuator contains a powerful spring. Spring is under tension, even when all air and electric lines are disconnected. Do not attempt to disassemble, service, or remove actuator without reading, understanding, and following instructions, otherwise injury or damage may result.

### **ACTUATOR REMOVAL**

1. Use a temporary air line to pressurize actuator to retract stem.
2. Remove bolts (#11A) and lock washers (#11B).
3. **CAUTION:** Slowly bleed air from actuator. Actuator will move away from the yoke.
4. Rotate actuator counterclockwise to unscrew it off from upper pinch bar (#9).

### **ACTUATOR INSTALLATION**

1. Lower actuator stem through the yoke (#11) and rotate actuator clockwise to screw it into upper pinch bar (#9).

2. Re-attach positive opening feature tab to upper pinch bar (#9) as shown in sleeve replacement step #8.
3. Replace actuator bolts and lock washers (#11A, 11B).

## **PFC AIR BAG REPLACEMENT**

**NOTE:** We recommend replacing O- ring and thread-seal when servicing air bag. O-ring and thread-seal should be obtained before beginning air bag replacement.

1. Turn off and disconnect air supply.
2. Measure and record length of adjusting screw (#21B) projecting from cylinder head.
3. Remove the spring adjusting screw (#21B) by loosening jam nut (#21D) and turning screw counterclockwise.
4. Obtain 2 tie rods the same diameter as rods (#16), but at least 10 inches longer than original cylinder rods.

Remove 2 tie rods (#16) on opposite sides of the actuator by loosening jam nuts and hex nuts (#16B, 16C). Temporary insert the two longer threaded rods in their place. Snug up nuts on the temporary rods.

Remove remaining tie rods (#16).

5. Slowly loosen rod nuts, alternating from one rod to the other. Walk cylinder head (#17) off cover tube, until cylinder head is no longer under spring tension. Remove threaded rods, washers and nuts.
6. Remove plastic cylinder cover (#15).
7. Remove spring button (#21A) and spring (#21).
8. Remove stem lock nut (#20B) and thread-seal (#20A).
9. Remove stem (#20).
10. Remove spring cap (#19) from air bag (#18) by loosening nuts and lock washers (#19B, 19C).
11. Remove air bag screws (#18A, 18B, 18C).
12. Remove air bag (#18) from actuator bottom (#14).
13. Remove O-ring (#14B) from actuator bottom.

14. Inspect actuator bearings (#14A). Replace if worn.
15. Install new O-ring (#14B) in actuator bottom.
16. Position new air bag (#18) on actuator bottom (#14).
17. Replace air bag hardware (#18A, 18B, 18C).
18. Insert stem (#20) up through the actuator bottom (#14).
19. Place spring cap (#19) over stem (#20) and air bag (#18).
20. Replace air bag screws, nuts, and lock washers (#19A, 19B, 19C).
21. Replace stem thread-seal (#20A).
22. Replace stem lock nut (#20B).
23. Replace spring (#21). Replace spring button (#21A).
24. Replace plastic cover tube (#15).
25. Set actuator top (#17) in place on spring button. Insert the 2 long tie rods through the actuator assembly, and use them to pull the actuator top down into place. Replace remaining tie rods (#16).  
Reattach hex nuts (#16B) and jam nuts (# 16C).

**Important:**

- Hex nuts first!
  - Do not over-tighten. **Max torque = 5 ft-lb!**
  - Then the thinner jam nuts go on.
  - Use two wrenches to counter tighten jam nuts against the hex nuts. Tighten the hex nuts and jam nuts against each other to 40 ft-lb. Do not tension the tie rods during this operation.
26. Replace jack bolt and jack bolt jam nut (#21B, 21D). Turn the jack bolt in to the same depth as before. Tighten jam nut.
  27. Remove the temporary tie rods, and reinstall the original tie rods.  
  
If valve fails to seat against line pressure, loosen jam nut and turn jack bolt in 1/4 turn at a time until valve holds line. Do not over tighten.
  28. Valve should now be ready for service.



ITEM	NOMENCLATURE
14	ACTUATOR BOTTOM
14A	BEARING, ACTUATOR BOTTOM
14B	"O" RING, ACTUATOR BOTTOM
14C	EXHAUST FILTER
15	ACTUATOR COVER TUBE
16	ACTUATOR TIE ROD
16A	WASHER, TIE ROD
16B	NUT, TIE ROD
16C	JAM NUT, TIE ROD
17	ACTUATOR TOP ASSEMBLY
18	AIR BAG
18A	SCREW, AIR BAG
18B	LOCK WASHER, AIR BAG
18C	NUT, AIR BAG
19	ACTUATOR SPRING CAP
19A	SCREW, AIR BAG
19B	LOCK WASHER, AIR BAG
19C	NUT, AIR BAG
20	ACTUATOR STEM
20A	THREADSEAL, ACTUATOR STEM
20B	LOCK NUT, ACTUATOR STEM
21	SPRING
21A	ACTUATOR SPRING BUTTON
21B	ACTUATOR JACK BOLT
21C	BEARING, JACK BOLT
21D	JAM NUT, JACK BOLT

**Questions?**

Contact **Onyx Valve Company**

Tel: 856-829-2888

Fax: 856-829-3080

**e-mail: [david@onyxvalve.com](mailto:david@onyxvalve.com)**

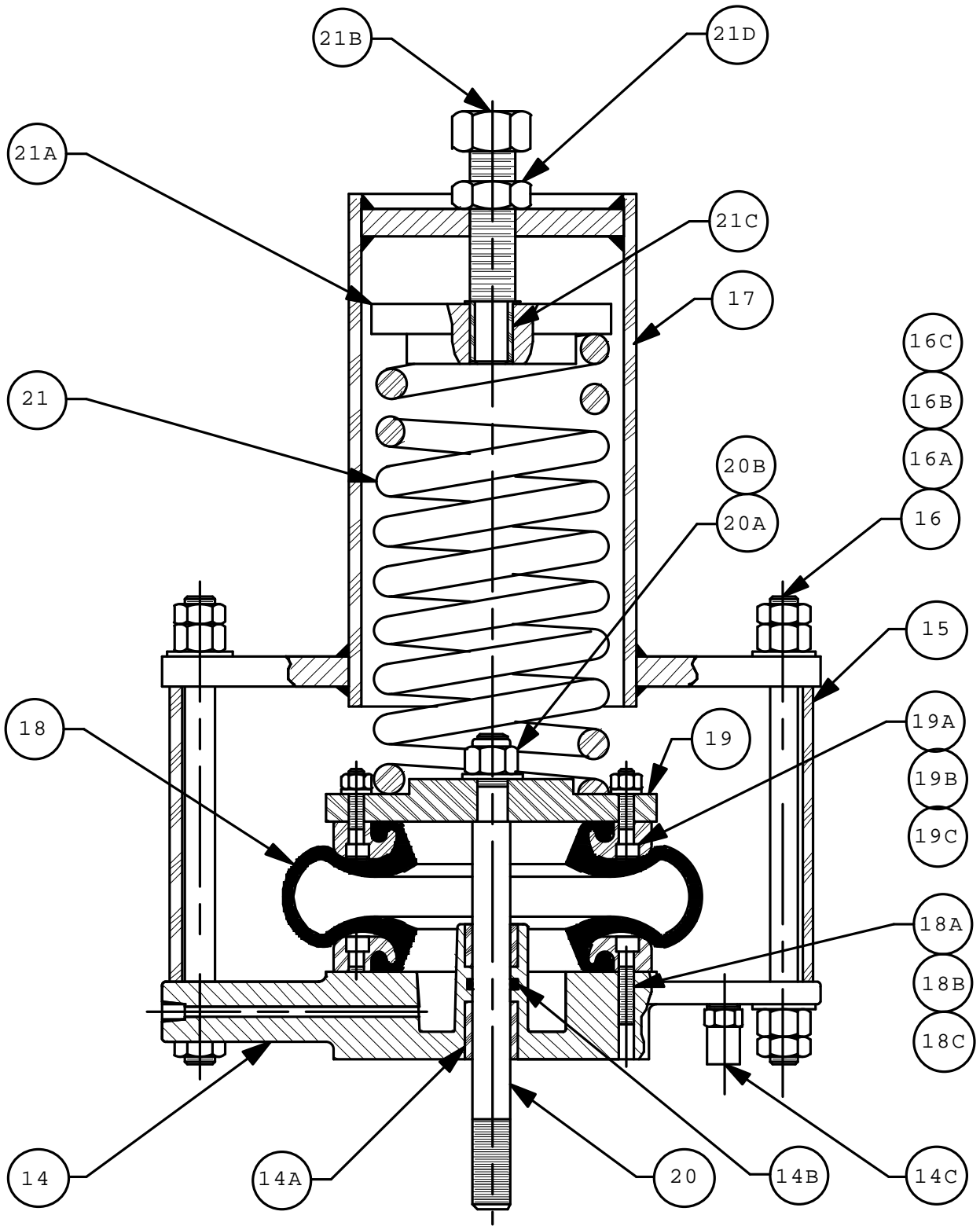

<b>ITEM</b>	<b>NOMENCLATURE</b>
<b>1</b>	SLEEVE
<b>2</b>	FLANGE, BACK-UP
<b>3</b>	SIDE FRAME
<b>4</b>	TIE ROD
<b>4B</b>	NUT, TIE ROD
<b>4C</b>	LK WASHER, TIE ROD
<b>4D</b>	JAM NUT, TIE ROD
<b>8A</b>	BOLT, POF
<b>8B</b>	WASHER, POF
<b>8C</b>	NUT, POF
<b>9</b>	UPPER PINCH BAR
<b>10</b>	LOWER PINCH BAR
<b>11</b>	YOKE
<b>11A</b>	BOLT, YOKE - ACTUATOR
<b>11B</b>	LOCK WASHER, YOKE - ACTUATOR
<b>23</b>	GUIDE ROD
<b>23A</b>	NUT, GUIDE ROD
<b>23C</b>	LK WASHER, GUIDE ROD
<b>23D</b>	JAM NUT, GUIDE ROD

