

Smart Box-4

Smart Box-4 protects progressing cavity pumps from over-pressure, run-dry situations, or seal water failure.

This latest generation Smart Box is versatile, easy to install, easy to use, and compatible with fixed speed or variable speed pumps.

The Smart Box-4 uses a solid state PLC and touch-screen for maximum reliability, eliminating wiring, mechanical push buttons, and lights. The touch-screen interface displays simple animated graphics so pump status and fault conditions are easy to understand. It comes standard in a fiberglass weatherproof (NEMA-4X) enclosure, with optional stainless steel also available. It operates on 120-230 VAC power and includes its own internal DC power supply.

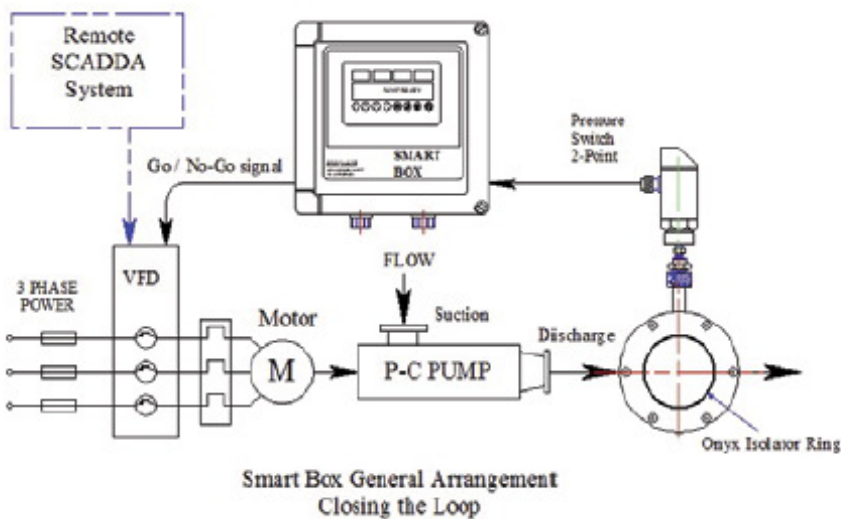

Working in combination with the Onyx Isolator Ring ensures reliable operation with abrasive slurries, viscous fluids, suspended solids, and corrosive liquids.

Our standard 2-point solid state pressure switch with digital readout is easier to set, more robust, and more accurate than traditional mechanical gauges and switches.



Smart Box-4 has one simple "permissive" contact for simpler wiring.

The Smart Box can also be configured to work as a Local Control Station, eliminating the need for an H-O-A (Hand-Off-Auto) switch or Reset button.

The Smart Box can turn seal flush water on and off, and can monitor a seal water flow switch.